

**2-Q PWM Servo – 10 A**

For Brushless-Commutated DC Motors up to 475 W

**SCP-B1-50-10**

- Brushless drive in a compact small module form
- Inputs and outputs via screw terminals
- User adjustable current limiter
- Wide range supply voltage between +20 and +50 VDC for different kinds of DC-power supplies
- Protected against overtemperature and over-current
- MOSFet-technology, efficiency 95%
- Continuous current up to 10 A
- Peak current up to 20 A

Basic drive description: The SCP-B1-50-10 drives are designed to drive DC brushless type motors. They require a single DC power supply for operation. The drives are to be used with a single motor. They have the functionality to operate as an independent speed control. The drives are protected against short circuits, under voltage, over temperature, and over current. It has multiple possibilities of operation and serves as a reliable choice for your motion control needs.

## Table of Contents

1. Safety & Installation .....	3
2. Specifications: .....	4
3. Drive Overview .....	6
4. Wiring.....	9
5. Explanation of Terminals & Potentiometers .....	14
6. Glossary .....	16
7. Description of Inputs and Outputs.....	21
8. Accessories & Options .....	23
9. Basic Troubleshooting.....	24
10. Warranties & Disclaimers .....	25
11. Dimensions .....	26

## Used Symbols



Indicates a warning or caution concerning operations that may lead to death or injury to persons, or damage to property if not performed correctly. In order to use the drive safely, always pay attention to these warnings.



Indicates a clarification of an operation, or contains additional explanations, or operational requirements for a procedure. Reading these notes is much recommended.

## 1. Safety & Installation



The SCP-B1-50-10 requires installation by qualified personal which must pay attention to significant safety and other regulatory standards. They should be thoroughly familiar with the entire system before beginning installation.



Before final operation of machine be sure to test hookup with motor disconnected from the load. Improper wiring could cause a “motor run away” condition, and cause serious injury or damage to the machine and personal.



Before starting installation of the SCP-B1-50-10, be sure that main power is disconnected. After powering the drive it should not be touched by hand or risk shock.



Take care that in case of regeneration or in brake operation the energy recovery must be buffered by the power supply and / or a braking module. Ensure with electronically stabilized power supplies that protection circuit isn't react.

Don't switch off the power supply while the motor is turning, in this case the drive could be destroyed by regeneration.

We recommend connecting a capacitor of 1000  $\mu$ F per each ampere output current close to power input, in parallel.



Do not repair or open drives enclosure. Result would result in personal injury and would void all warranties.



The SCP-B1-50-10 is not complying with the European directive EN 61800-3 (1996) for his own but the following points can be helpful:

- A metal mounting plate with correct grounding is mandatory.
- For installation purposes, tooth lock washers have to be used.
- For most wiring schemes, only shielded cables are admissible, to suppress interference with other devices. Damaged items have to be replaced.
- Provide for a large contact area between shields and mounting plate.
- The motor has to be grounded in the prescribed manner.
- The drive is an Electrostatic Sensitive Device (ESD). Electrostatic discharge needs to be avoided



### NOTE:

Certain applications may involve special requirements. Consult Factory!

## 2. Specifications:

### 2.1 Electrical Data

Power Supply Voltage	+20 to +50 VDC (Residual ripple <5 %) (The lower limit is monitored by integrated undervoltage trip) <b>WARNING: Do not exceed 50V. Overvoltage will damage the drive.</b>
Nominal Current	10 A
Peak Current	20 A
Maximum Power (only achievable with additional heatsink < 1.8 K / W & proper mounting over a current of 3.5 A.)	475 W
Switching Frequency	20 kHz
Efficiency	95 %
Induction Specification & caution for low inductance motors	Optional choke modules are often an economical solution for low inductance or other motors, if an overheating situation occurs in regular intervals. Contact factory service for details.
Power and signal terminals	The diameter must be suited for the connecting wires of the current load. The recommendation is 1,5 mm <sup>2</sup> (AWG16), the minimum is 0,13 mm <sup>2</sup> (AWG28). Maximum wire diameter with respect to the terminal is 2,5 mm <sup>2</sup> (AWG14). Strip the wire insulation of the cables on a length of maximal 8 mm. For stranded wire, use end sleeves with the corresponding length.

## 2.2 Mechanical Data

Mechanical Dimensions L x W x H	94 x 55 x 39 mm
Weight	140 g
Mounting	M3 screws

## 2.3 Ambient Conditions

Operation Temperature	-10 to +45 °C
Storage Temperature	-40 to +85 °C
Humidity (Non Condensing)	20 % to 80 % RH
Overtemperature Protection	+80 °C

## 2.4 Digital and Analog Inputs

Disable ( <i>Dis</i> )	Open Collector / TTL / CMOS / Switch
Direction ( <i>Dir</i> )	Open Collector / TTL / CMOS / Switch
Hall 1, 2, 3 ( <i>S1, S2, S3</i> )	TTL, +6 VDC; Resistance = 1 kOhm
Set value ( <i>Sv</i> )	Analog 0 – +5 VDC ; Resistance > 100 kOhm

## 2.5 Outputs

Auxiliary Voltage Outputs S+	+6 V / 20 mA
------------------------------	--------------

### 3. Drive Overview

#### 3.1 Block Diagram

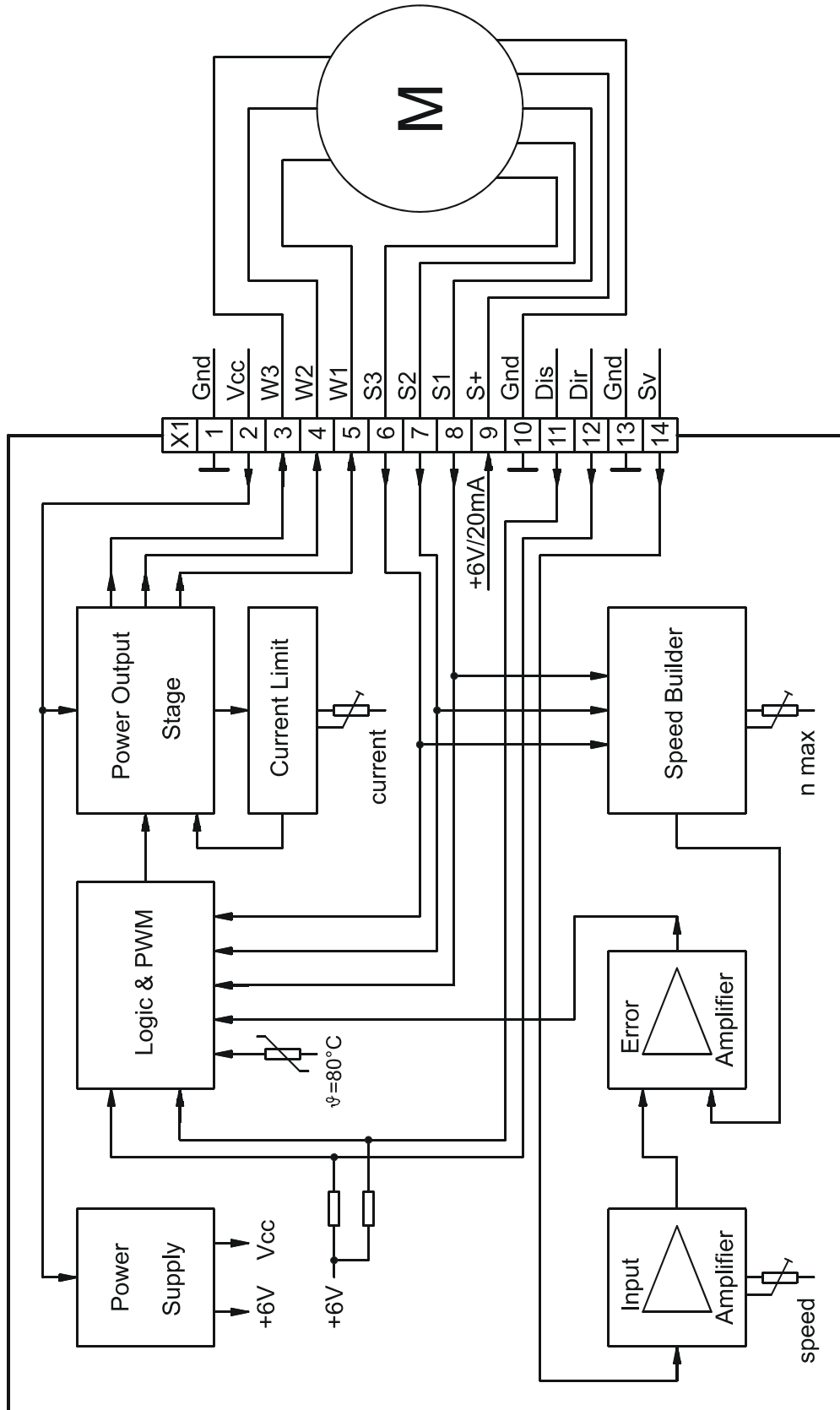

### 3.2 Input & Output Schematics

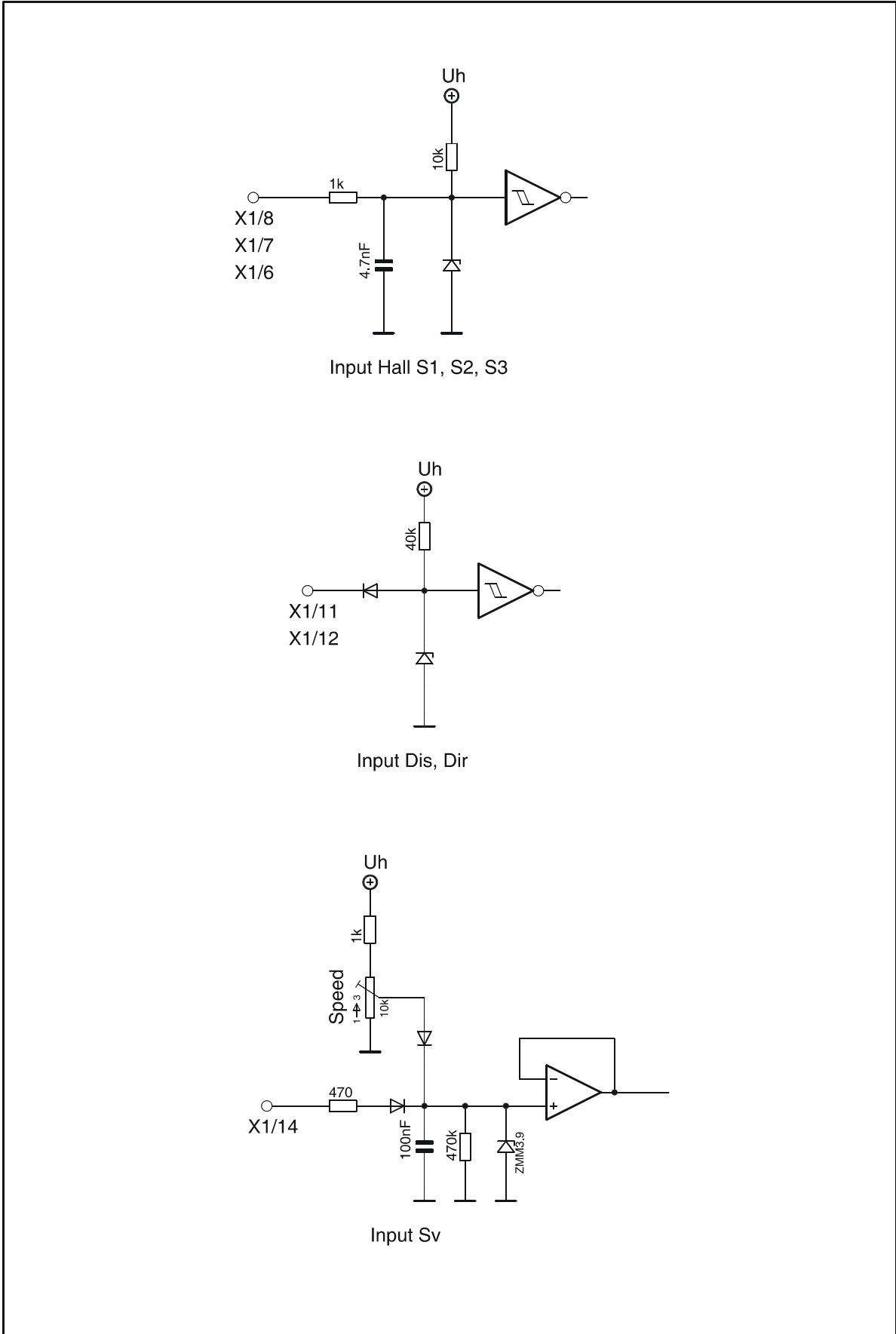

### 3.3 Control Elements

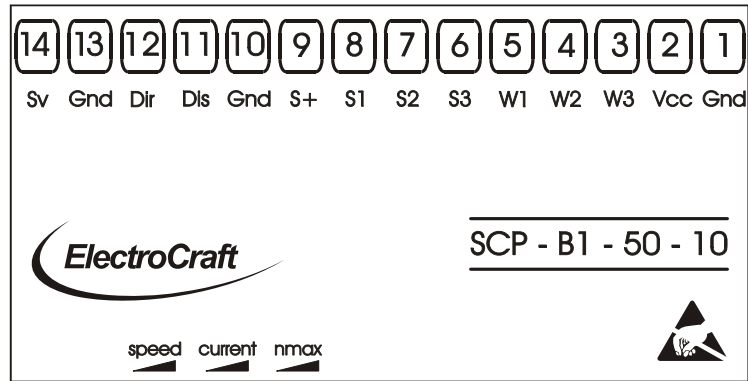

### 3.4 Operation Modes

#### Hall Mode

At hall mode the feedback information is coming from hall switches which are mounted in the motor or a hall encoder which is mounted at the motor. The speed regulation is good at each load condition and qualified for each application to control the speed of a system also for high speed application.



## 4. Wiring

According to the safety directives, a correct cable selection is mandatory. Regular inspection is advisable. Damaged, burned or kinked items have immediately to be exchanged.

### Power (*V<sub>cc</sub>* - *GND*)

- Normally no shielding required.
- When connecting several amplifiers to the same supply pack, use star point wiring.

### Motor Wiring (> 30 cm)

- Only shielded cables are recommended.
- Connect the shield to the ground lug of the servo amplifier.
- A separate cable has to be used.
- Choke modules are useful to reduce PWM-pulses.

### Connection to hall (> 30 cm)

- Only shielded cables are recommended.
- Connect the shield to the controller.
- A separate cable has to be used.

### Analog Signals (*S<sub>v</sub>*)

- In most cases no shielding required. This may be different for low level signals or in an environment with strong magnetic interference.
- Connect the shield on either end of the cable. For 50/60 Hz interference, remove the shield on one side.

### Digital Signals (*Dis*; *Dir*)

- No shielding required.

To verify a trouble-free operation and the conformity to CE regulation, it makes only sense to test the system as a whole, with all components installed (motor, amplifier, supply pack, EMC filters cables etc.).



Note: To improve the noise immunity, always connect unused logical inputs to a fix potential (*GND* or *+6V*).

### 4.1 Wiring Example I

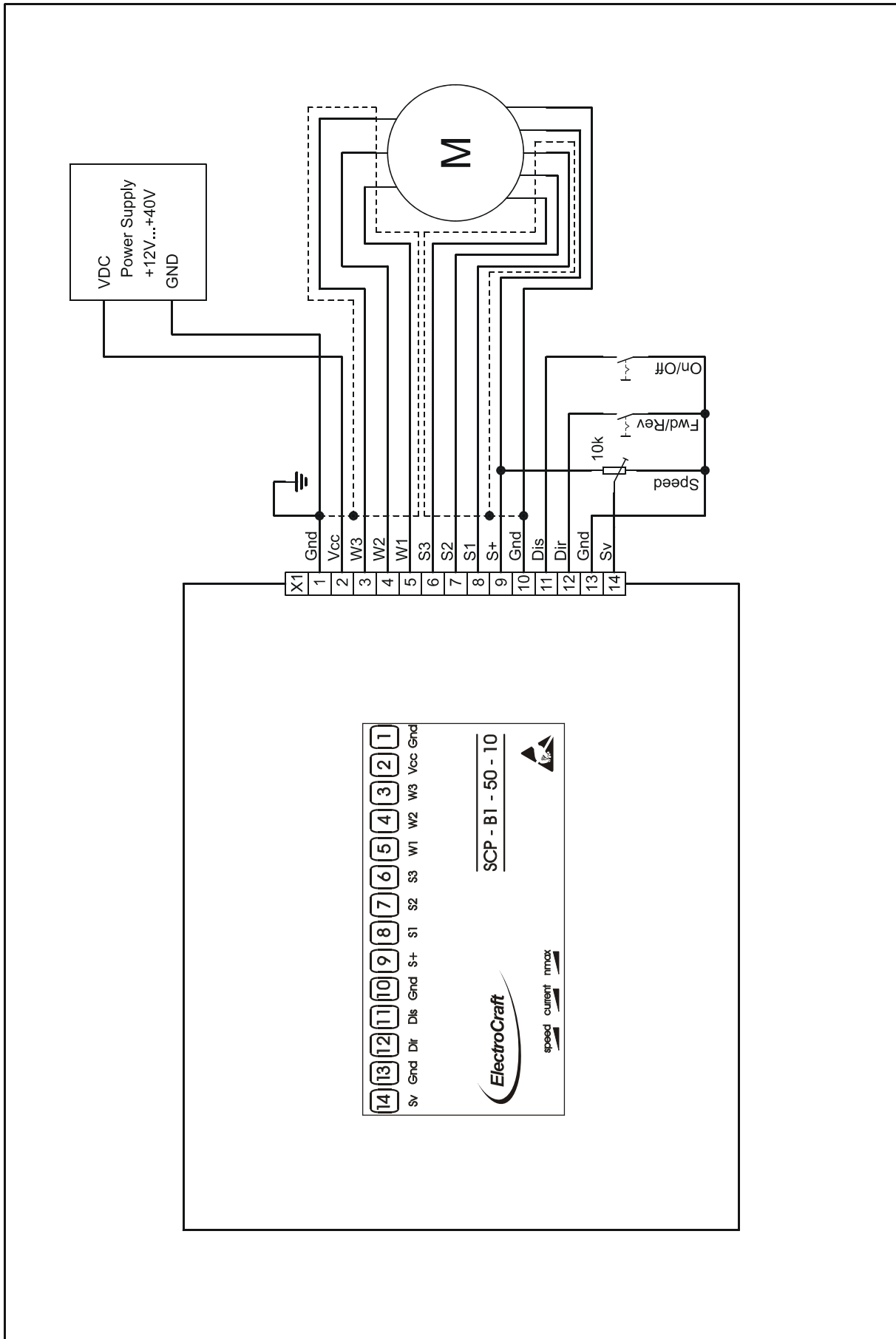

#### 4.1.1 Adjustment procedure for Example I

1. Potentiometer pre setting refer chapter 5.2.
2. Set the internal *speed* potentiometer to the right stop.
3. To activate the drive switch the *Dis* input to ground.
4. Set the external speed potentiometer to maximum speed.
5. Turn the potentiometer *nmax*, until the desired maximum speed is reached.
6. Adjust with the *current* potentiometer the maximum motor current to a value requested by you. It is of major importance that this value is lower than the maximum admissible constant current (see motor data sheet). To measure the motor current use a current probe in one of the motor cables with a oscilloscope or a multimeter.
7. To change rotation direction of the motor connect the *Dir* input to ground.



Note: In case of using the switch for *Dir* refer chapter 7.1.

## 4.2 Wiring Example II – Minimal Wiring

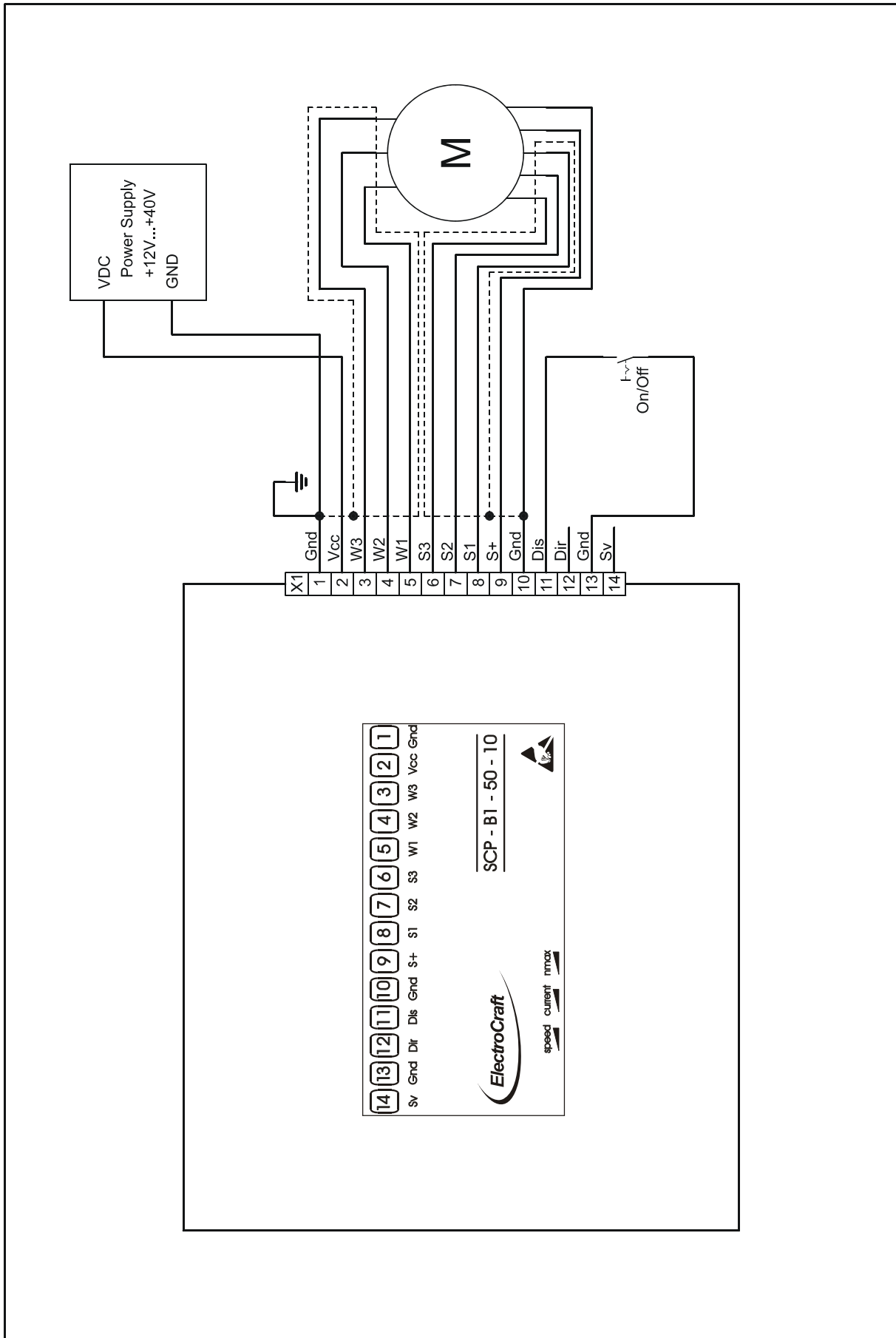

#### 4.2.1 Adjustment procedure for Example II

1. Potentiometer pre setting refer chapter 5.2.
2. To activate the drive switch the *Dis* input to ground.
3. Set the internal *speed* potentiometer to maximum speed.
4. Turn the potentiometer *nmax*, until the desired maximum speed is reached.
5. Adjust with the *current* potentiometer the maximum motor current to a value requested by you. It is of major importance that this value is lower than the maximum admissible constant current (see motor data sheet). To measure the motor current use a current probe in one of the motor cables with a oscilloscope or a multimeter.

## 5. Explanation of Terminals & Potentiometers

### 5.1 Terminals

Terminal	Label	Description
X1		<p>Pin 1 &amp; 2 connect to power supply.                      Pin 3 &amp; 4 &amp; 5 connect to motor.                      Pin 6 &amp; 7 &amp; 8 input for hall signals.                      Pin 9 voltage output +6 VDC.                      Pin 10 GND.                      Pin 11 input Disable (<i>Dis</i>).                      Pin 12 input Direction (<i>Dir</i>).                      Pin 13 GND.                      Pin 14 input set value (<i>Sv</i>).</p>

## 5.2 Potentiometers

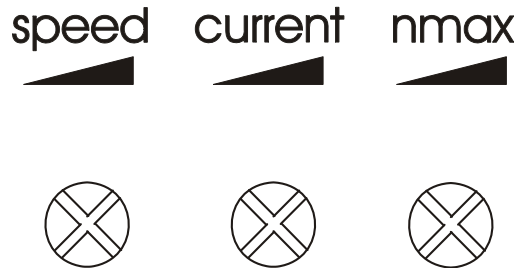

Potentiometer	Function	Turning to the Left (ccw)	Turning to the Right (cw)
<i>speed</i>	Set the motor speed	Decrease motor speed	Increase motor speed
<i>current</i>	Set value for max. current	Reduce the current	Increase the current
<i>nmax</i>	Definition of max. number of revolutions	Value is decreased	Value is increased

### Potentiometer setting for start up:

<i>Speed</i>	<i>current</i>	<i>n max</i>
Left stop	Middle	Middle

## 6. Glossary

### ***nmax***

Use this potentiometer to adapt the desired maximum speed to the amplitude of the present set value. For Example: if maximum of 5V is to be used for maximum speed then send 5V and adjust that maximum with the *nmax* potentiometer

Take care not to exceed meaningful limits. An exaggerated value may avoid to control the drive and making it impossible e.g. to line-up the system in speed control operation under load.

### ***current***

The following action requires the motor to be operated with maximum load. The motor current may be measured e.g. using current probe with effective value display, or by means of an ammeter located in the motor line.

*current* decide on the maximum possible motor current.

The following limits have to be observed:

- Left stop: 5 % of rated current of 10 A
- Right stop: 100 % of rated current + (0 – +20 %)

Note:



Do not overheat the motor. For this reason, the *I<sub>max</sub>* limit should always be selected lower than the maximum admissible constant current.

The peak current of the drive can be rise up to 20 A.

### ***speed***

The function for the *speed*-potentiometer is to adjust the motor speed.

### ***Hall mode***

This is a closed loop speed mode which is using the hall signals as a feedback input for the speed.



### ***Brushless motor***

A class of motors that operate using electronic commutation of phase currents, rather than electromechanical (brush-type) commutation. Brushless motors typically have a permanent magnet rotor and a wound stator.

### ***Commutation***

Is a term which refers to the action of steering currents or voltages to the proper motor phases so as to produce optimum motor torque. In brush type motors, commutation is done electromechanically via the brushes and commutator. In brushless motors, commutation is done by the switching electronics using rotor position information obtained by Hall sensors.

### ***Hall sensor***

Is a feedback device which is used in a brushless servo system to provide information for the amplifier to electronically commutate the motor. The device uses a magnetized wheel and hall effect sensors to generate the commutation signals.

### ***Back EMF***

The voltage generated when a permanent magnet motor is rotated. This voltage is proportional to motor speed and is present regardless of whether the motor winding(s) are energized or de-energized.

### ***Closed loop***

This is broadly applied term, relating to any system in which the output is measured and compared to the input. The output is then adjusted to reach the desired condition. In motion control, the term typically describes a system utilizing a velocity and/or position transducer to generate correction signals in relation to desired parameters.

### ***Cogging***

A term used to describe non-uniform angular velocity. Cogging appears as jerkiness, especially at low speeds.

### ***Continuous rated current***

The maximum allowable continuous current a motor can handle without exceeding the motor temperature limits

### ***Continuous stall torque***

Is the amount of torque at zero speed, which a motor can continuously deliver without exceeding its thermal rating. To determined by applying DC current through two windings with locked rotor, while monitoring temperature. It's specified with motor windings at maximum rated temperature and 25 °C ambient temperature, motor mounted to a heat sink. Refer to individual specs for heat sink size.

### ***Controller***

This term describes a functional block containing an amplifier, power supplies, and possibly position-control electronics for operating a servomotor or step motor.

### ***Demag current***

Is the current level at which the motor magnets will start to be demagnetized. This is an irreversible effect, which will alter the motor characteristics and degrade performance.

### ***Drive***

It's an electronic device that controls torque, speed and/or position of an AC or brushless motor. Typically a feedback device is mounted in or on the motor for closed-loop control of velocity and position.

### ***Driver***

Is the electronics which convert step and direction inputs to high power currents and voltages to drive a step motor. The step motor driver is analogous to the servomotor amplifier's logic.

### ***Efficiency***

The ratio of power output to power input.

### ***Encoder***

Is a feedback device which converts mechanical motion into electronic signals. The most commonly used, rotary encoders, output digital pulses corresponding to incremental angular motion. For example, a 1000-line encoder produces 1000 pulses every mechanical revolution. The encoder consists of a glass or metal wheel with alternating transparent and opaque stripes, detected by optical sensors to produce the digital outputs.

### ***Feedback***

It is a signal which is transferred from the output back to the input for use in a closed loop system.

### ***Four quadrants***

Refers to a motion system which can operate in all four quadrants; i.e., velocity in either direction and torque in either direction. This means that the motor can accelerate, run, and decelerate in either direction.

### ***Gain***

The dynamical behaviour of the servo amplifier must be compatible to the particular connected motor. The adjusting procedure is performed using the *Gain* potentiometer. A bad adaptation (i.e. if the *Gain* value has been selected too high) can be easily recognized by excessive motor vibration or noise. Consequential mechanical damages cannot be excluded; furthermore an overtemperature situation may arise, due to high currents inside the motor.

### ***Inductance***

The electrical equivalent to mechanical inertia; that is, the property of a circuit, which has a tendency to resist current flow when no current is flowing, and when current is flowing has a tendency to maintain that current flow.

### ***NTC - Negative Temperature Coefficient***

A negative temperature coefficient thermistor is used to detect and protect a motor winding from exceeding its maximum temperature rating it is also used in a servo amplifier. Resistance of the device decreases with an increase in temperature.

### ***Open-loop***

A system in which there is no feedback. Motor motion is expected to faithfully follow the input command. Stepping motor systems are an example of open-loop control.

### ***Pulse Width Modulation (PWM)***

1. A PWM controller (amplifier) switches DC supply voltage on and off at fixed frequencies. The length of the on/off interval or voltage waveform is variable.
2. Pulse width modulation (PWM), describes a switch-mode (as opposed to linear) control technique used in amplifiers and drivers to control motor voltage and current. PWM offers greatly improved efficiency compared to linear techniques.

### ***Regeneration***

The action during motor braking, in which the motor acts as a generator and takes kinetic energy from the load, converts it to electrical energy, and returns it to the amplifier.

### ***Resonance***

Oscillatory behavior caused by mechanical limitations.

### ***Ringling***

Is an oscillation of a system following a sudden change in state.

### ***Speed***

Describes the linear or rotational velocity of a motor or other object in motion.

### ***Tachometer***

A small generator normally used as a rotational speed sensing device. The tachometer feeds its signal to a control which adjusts its output to the motor accordingly (called "closed loop feedback" control).

### ***Thermal protection***

A thermal sensing device mounted to the motor to protect it from overheating. This is accomplished by disconnecting the motor phases from the drive in an over temperature condition.

**Torque**

Is a measure of angular force which produces rotational motion. This force is defined by a linear force multiplied by a radius; e.g. lb-in or Nm. Torque is an important parameter of any motion control system.

**Torque mode**

In this mode the driver controls only the current of the motor. The speed of the motor depends on the load because only the output force of the motor is regulated.

**Two Quadrants**

Refers to a motion system which can operate in two quadrants by changing the direction of the motor speed ore in one quadrant with active accelerate and decelerate.

**Watt**

One horsepower equals 746 watts.

## 7. Description of Inputs and Outputs

### 7.1 Digital Inputs

**Dis - Disable: Activating or Disabling the Output Stage**

If the *Dis* input X1/11 is at GND potential or LO, the output stage remains in the locked state. The motor stands still or slow down without brake. The output stage is activated if not wired at all or a voltage signal >3.5 V is set to the *Dis* input.

Additional information about the schematic refer chapter 3.2.

Range of Input Voltage	0 to +24 VDC
Input Impedance	>100 kOhm
Drive disabled	<0.6 VDC or connected to GND
Drive activated	>3.5 VDC or open

**Dir - Direction: Changing the Direction of the Rotation**

If the *Dir* input X1/12 is at LO the motor turns in clockwise or counter clockwise, at HI or open he works in the opposite direction. The direction depends by the commutation sequence of the motor.

Additional information about the schematic refer chapter 3.2.

Range of Input Voltage	0 to +24 VDC
Input Impedance	>100 kOhm
Direction e.g. CCW-rotation	<0.6 VDC or connected to GND
Direction e.g. CW-rotation	>3.5 VDC or open

Note:



It is to avoid changing the direction on fly; otherwise the motor also the drive can be damaged. For changing the direction please follow this way:

- Disable to LO, wait until motor has stopped
- Change the *Dir* level
- Enable auf HI, motor is working in the other direction

**S1 / S2 / S3: Hall Feedback of the Motor**

The hall inputs X1/5, X1/6 and X1/7 are connected to the hall signals of the motor. The supply voltage is given by the S+ output at X1/9 and GND (X1/10). The drive needs the signals to do the commutation and control the speed.

Additional information about the schematic refer chapter 3.2.

Range of Input Voltage	0 to +6 VDC
Input Impedance	>10 kOhm
Permanent Input Protection	-0.6 to +24 VDC
High level	>2,4 VDC
Low level	<1 VDC

### 7.3 Analog Inputs

#### Sv: Set Value Input for Speed

An external analog signal for speed entered using Sv input X1/14. If the voltage is lower than 0.5 V, the motor stops. If the voltage is positive the drive is working in the regulation area. Over 5 V the motor is unregulated with a limited maximum speed through the *nmax* potentiometer.

Additional information about the schematic refer chapter 3.2.

Range of Input Voltage	0 V to +5 V
Input Impedance	>100 kOhm
Permanent Input Protection	-0,6 V to +30 V

Remark:



If the external Sv input is used for the set value the *Speed* potentiometer has to rotate to the right stop.

## 8. Accessories & Options

- Choke modules
  - IA3100 (with 3 x 50 µH)
  - and IA3101 (with 3 x 100 µH)

## 9. Basic Troubleshooting

### ***Motor runaway***

- The logic of the hall connection is permuted.
- Reduce the maximal speed with pot *nmax*.

### ***Motor noise***

- Use additional choke in the motor

### ***Motor has no torque***

- Increase the admissible current with *current* pot.

### ***Motor drifts at standstill***

- The input value for the set value isn't stable.

### ***Motor is going hot***

- Use an additional choke in series with the motor (see accessories).

### ***Motor speed too low***

- Increase the range with pot *nmax*.
- Increase the admissible current with *current* pot.
- Supply voltage too low.

### ***No motion even though enable is on***

- Check power supply and the wiring.
- Overheating protection is active.
- Check the polarity of the motor windings and hall signals.
- Is the phasing (120°) of the hall correct?
- The polarity of the motor windings or hall signals is permuted.
- The feedback loop is open. Check wiring.

### ***Over temperature***

- Use an additional cooling.
- Reset the amplifier.

Note:



Beware that the maximal working temperature of 80°C in the driver is not reached; otherwise the drive will be switched off.



## 10. Warranties & Disclaimers

- Contents are subject to change without notice.
- Electrocraft will not be liable in any way for direct, indirect, incidental, or consequential damages caused by the use of this product or document.
- Per Electrocraft's Terms & Conditions, the user of Electrocraft's accepts all responsibility and risks involved with applying this product into their machinery and indemnifies Electrocraft against all damages.
- Any reproduction of this product and document is strictly prohibited!

### Limited Warranty:

Electrocraft products unless otherwise stated in specifications, are warranted for a period of 18 months from date of shipment, to be free from defects in materials, workmanship, and to conform to the specifications. Liability under this warranty shall be limited to the repair or replacement but not to the installation of any defective product at Seller's option. Products will be repaired or replaced at the Seller's option. Under no circumstance shall the user repair or modify the product. Failure to adhere to this will void all warranty.

For Warranty, Repair, or Technical Assistance contact:

#### Customer Support, North America / USA & Canada

Motion Control Technologies: (800) 697-6715

Email: [info@electrocraft.com](mailto:info@electrocraft.com)

#### Customer Support, Europe (except Germany), Middle East, Africa, Australia, Central & South America

Customer service at +44 (0) 127 050 8800

Email: [EMEAsales@electrocraft.com](mailto:EMEAsales@electrocraft.com)

#### Customer Support, Germany

Customer service at +49 (0) 711 727205 0

Email: [info@electrocraft.de](mailto:info@electrocraft.de)

## 11. Dimensions

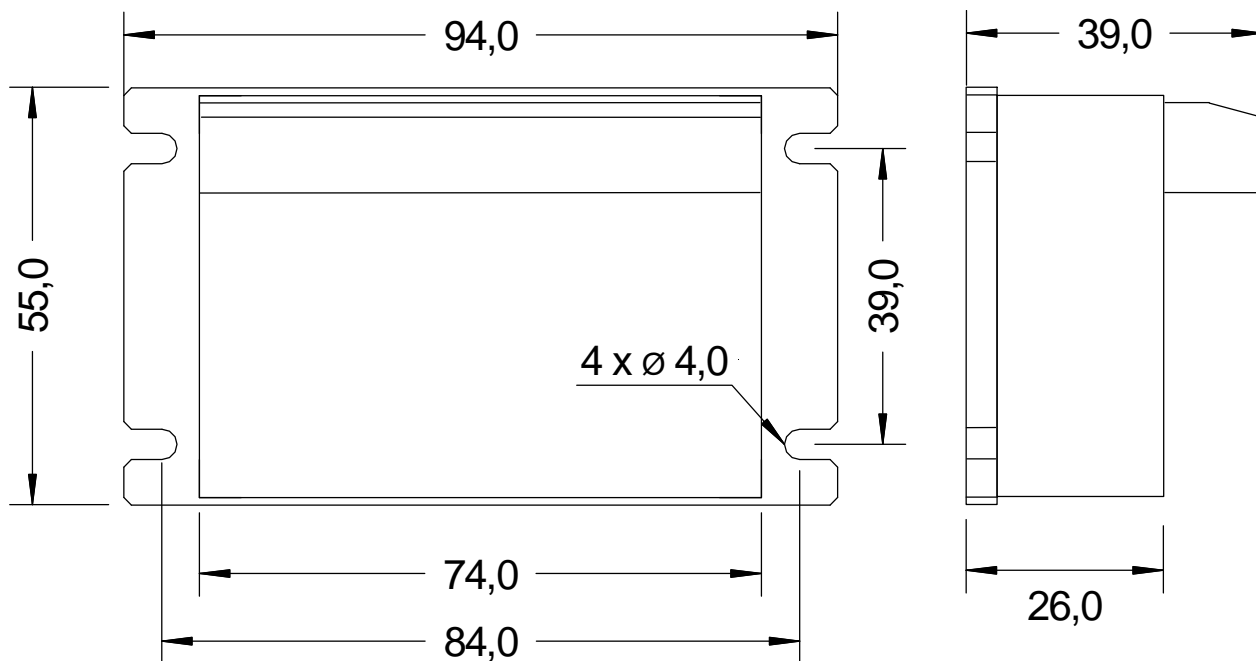

All dimensions in mm.

SCP-B1-50-10\_E09 Subject to change without prior notice.